

X055ML Digital Security Safe

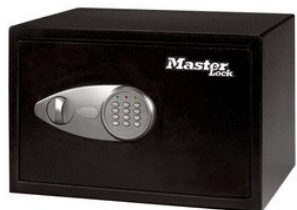

A4



- Steel construction provides added security
- Programmable digital lock allows you to choose your combination plus it comes with an override key which makes entry in the safe secure yet simple
- 2 solid steel live-locking bolts provide additional security
- Concealed hinges for added protection and security
- 4AA
- May be bolted down to prevent unauthorized removal (hardware included)

This Master Lock product is a great solution for protecting and securing small but precious valuables. Custom foam interior keeps important valuables protected from damage during storage.

H x W x D

X055ML
22.1 cm x 35.01 cm x 24.6 cm

x x

21.59 cm x 34.54 cm x 22 cm

16.44 L

6.4 kg

Retail Boxed Packaging, Retail Boxed Packaging

1

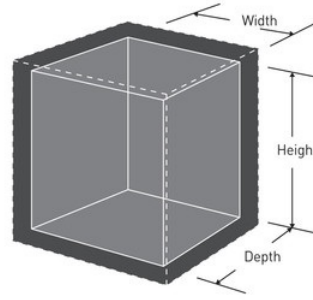

Master Lock Europe S.A.S.

10 avenue de l'arche - Le Colisée Gardens, bâtiment A - 92 400 Courbevoie - La Défense - France
O:+33-1-41437200 | F:+33-1-41437204
www.masterlock.eu